

ABR300UC SERIES
300 Watts
KEY FEATURES

- U Bracket Switching Power Supply
- Universal Input: 90-264 VAC
- Active P.F.C. Function, PF>0.9
- 300W Conduction Cooling
- 300W Convection with 18CFM FAN
- Over Current / Over Voltage /
Over Temperature / Short Circuit Protection
- Current Share Function
- 3-Year Product Warranty

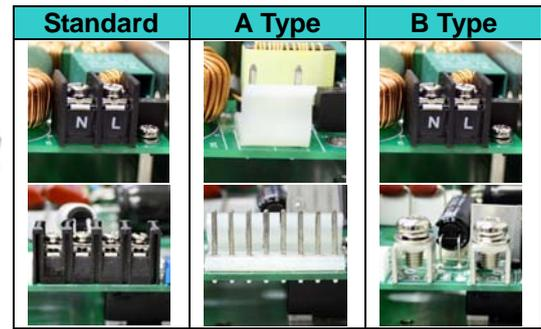

(In Progress)

ELECTRICAL SPECIFICATIONS

All specifications valid at normal input voltage, full load and +25°C after warm-up time unless otherwise stated.

Model No.	ABR300UC-12S	ABR300UC-24S	ABR300UC-28S	ABR300UC-48S
Max Output Wattage (18CFM FAN) (W)	300W	300W	308W	300W
Max Output Wattage (Conduction Cooling) (W)	300W			
Input	Voltage			
	90-264 VAC			
	Frequency (Hz)			
	50/60 Hz (47-63 Hz)			
	Current (Full load)			
<4.0 A (100 VAC) / <2.0 A max. (200 VAC)				
Inrush Current (<2ms)				
< 70 A max. (115 VAC) / < 90 A max. (230 VAC)				
Power Factor (typ.)				
PF>0.95 (100 VAC) / PF>0.9 (230 VAC) at Full Load				
Output	Voltage (V.DC.)			
	12V	24V	28V	48V
	Voltage Accuracy			
	±2%			
	Trim (V.DC)			
	11.64 ~ 12.3V	23.28 ~ 24.7V	27.12 ~ 28.86V	46.56 ~ 49.48V
	Current (max.)			
	25	12.5	11	6.25
	Line Regulation (LL-HL) (typ.)			
	±1%			
	Load Regulation (10-100%) (typ.)			
	±5%	±3.5%	±3%	
Minimum Load				
0%				
Maximum Capacitive Load				
5000 uF	2500 uF	2500 uF	1250 uF	
Ripple & Noise (max.)				
150mVp-p	200mVp-p	200mVp-p	300mVp-p	
Efficiency (%) (at 230 VAC)				
88.5%	89%	89%	90%	
Remote Sensing				
Provided				
Hold-up Time (at 230 VAC)				
10 ms min.				
Protection	Over Power Protection			
	Auto recovery			
	Over Voltage Protection			
	Auto recovery			
Over Temperature				
Auto recovery				
Short Circuit Protection				
Auto recovery, Hiccup mode				
Isolation	Input-Output (V.AC)			
	3000V			
	Input-FG (V.AC)			
1500V				
Output-FG (V.AC)				
500V				
Environment	Operating Temperature			
	-40°C...+65°C (with derating)			
	Storage Temperature			
	-40°C...+85°C			
	Temperature Coefficient			
	±0.05%/°C (0~50°C)			
Humidity				
20~95% RH (Non condensing)				
MTBF				
>200,000 h @ 25°C (MIL-HDBK-217F)				
Vibration				
10~500Hz, 2G 10min./1cycle, 60min. each along X, Y, Z axes.				
Physical	Dimension (L x W x H)			
	6.0 x 4.18 x 1.41 Inches (150.0 x 106.0 x 36.0 mm) Tolerance ±0.5 mm			
	Weight			
In Progress				
Cooling Method				
Conduction cooling				
Safety	Agency Approvals			
CE, UL60950-1 (In Progress)				
EMC	EMI (Conducted & Radiated Emission)			
	EN 55022 Conducted Class B & Radiated Class A (In Progress)			
EMS (Noise Immunity)				
EN 55024 · EN61000-4-2,3,4,5,6,8,11				

NOTE

1. Ripple & Noise are measured at 20MHz of bandwidth with ceramic 0.1uF & chemi-con KY 47uF parallel capacitor.

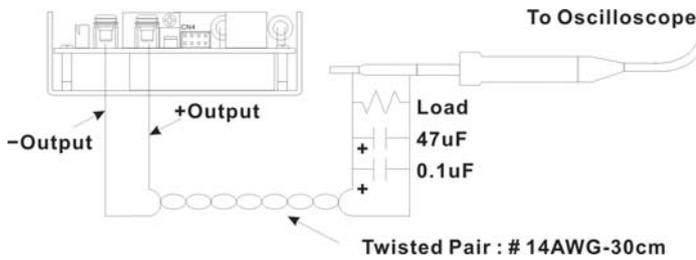

A 30cm twisted pair of no.14 AWG copper wire is connected to a 47uF and 0.1uF capacitor of proper polarity and voltage rating. The oscilloscope probe ground led should connect right to the ground ring of the probe and be as short as possible. The oscilloscope bandwidth should be at 20MHz and connected to AC ground.

2. Hold-up Time measured at 90% Vout.

3. Strongly recommend to conduct this test with DC Voltage. If customer wishes to test with AC Voltage, please disconnect all Y-Capacitors within Arch power supply.

4. The ABR300UC Series should be conduction-cooled. Use a heatsink or fan to dissipate heat.

5. Current Share:

- (a.)The output voltage difference of each parallel single element should be less than 0.2V.
- (b.)Output power at parallel operation = rated power per unit x number of unit x 90%
- (c.)Connect in parallel no more than 2 units. Please contact ARCH for advice if more than 2 is needed.

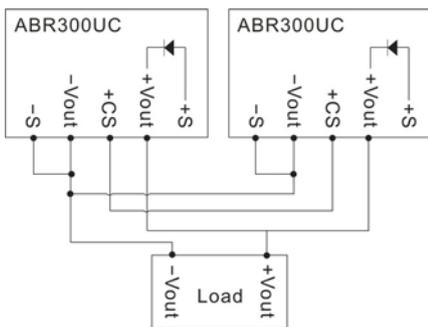

DERATING

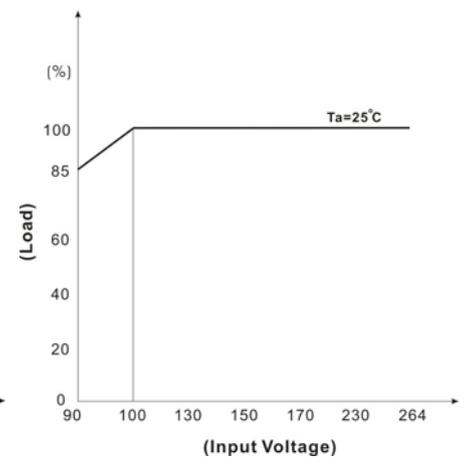
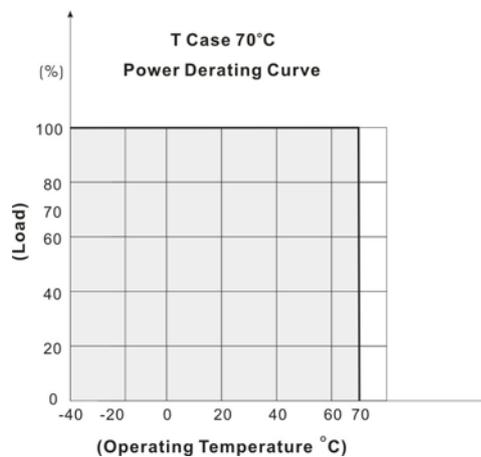
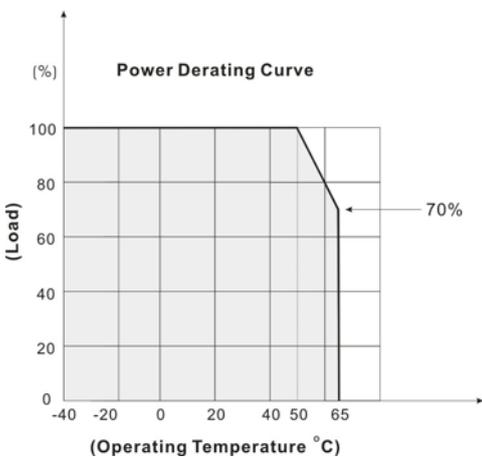

MECHANICAL DIMENSION (Top View)

Standard

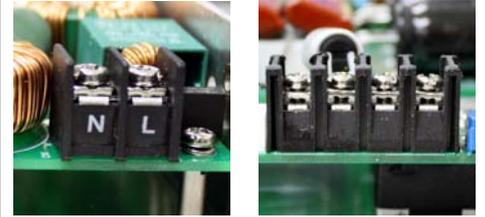
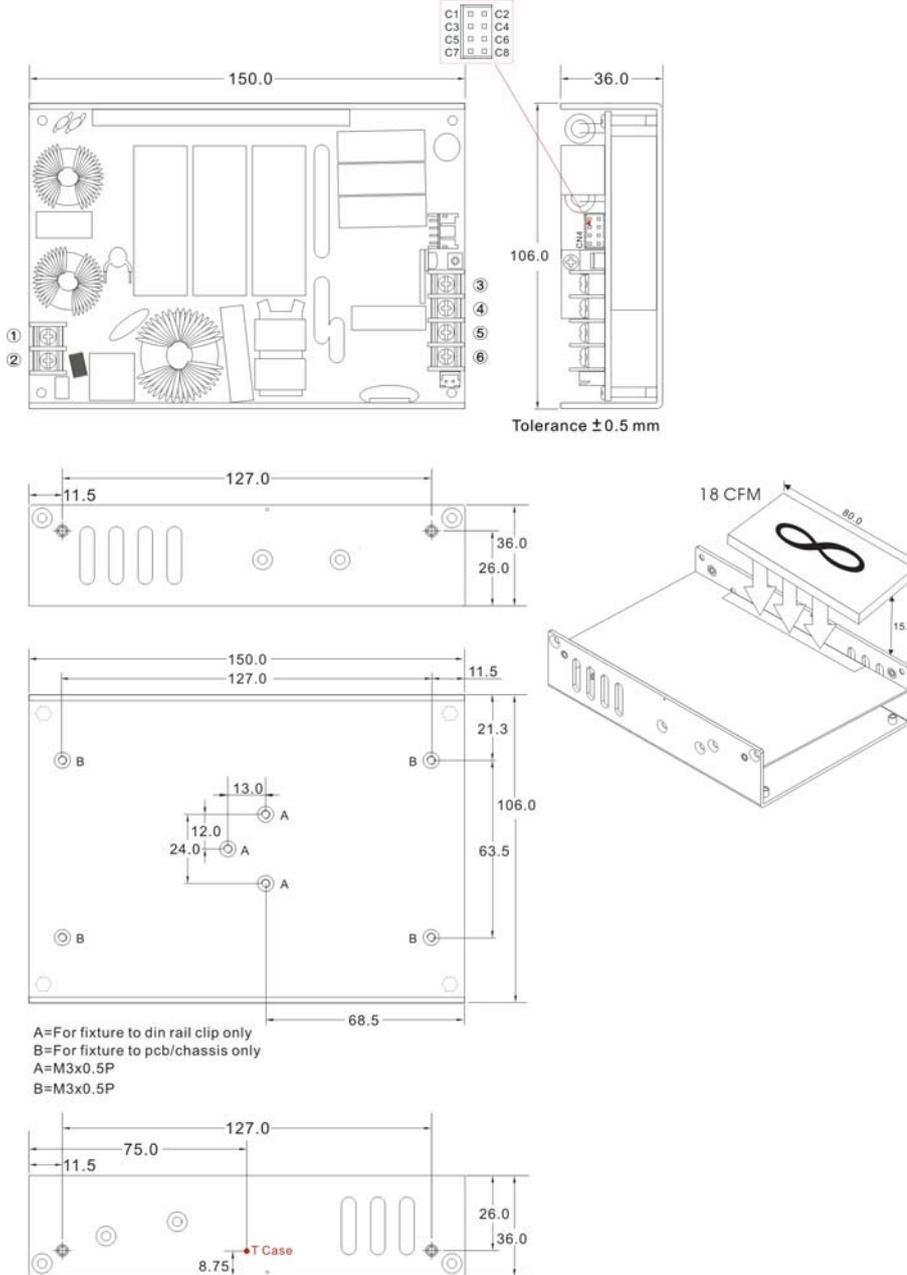

Terminal Pin

PIN#	Single
1	AC IN (N)
2	AC IN (L)
3~4	+DC OUT
5~6	-DC OUT

Connector Pin (CN4)

PIN#	Single
C1	NC
C2	-V
C3	NC
C4	NC
C5	ENA
C6	NC
C7	CS
C8	NC

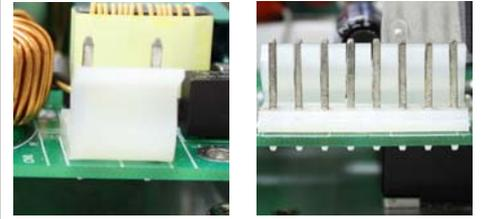
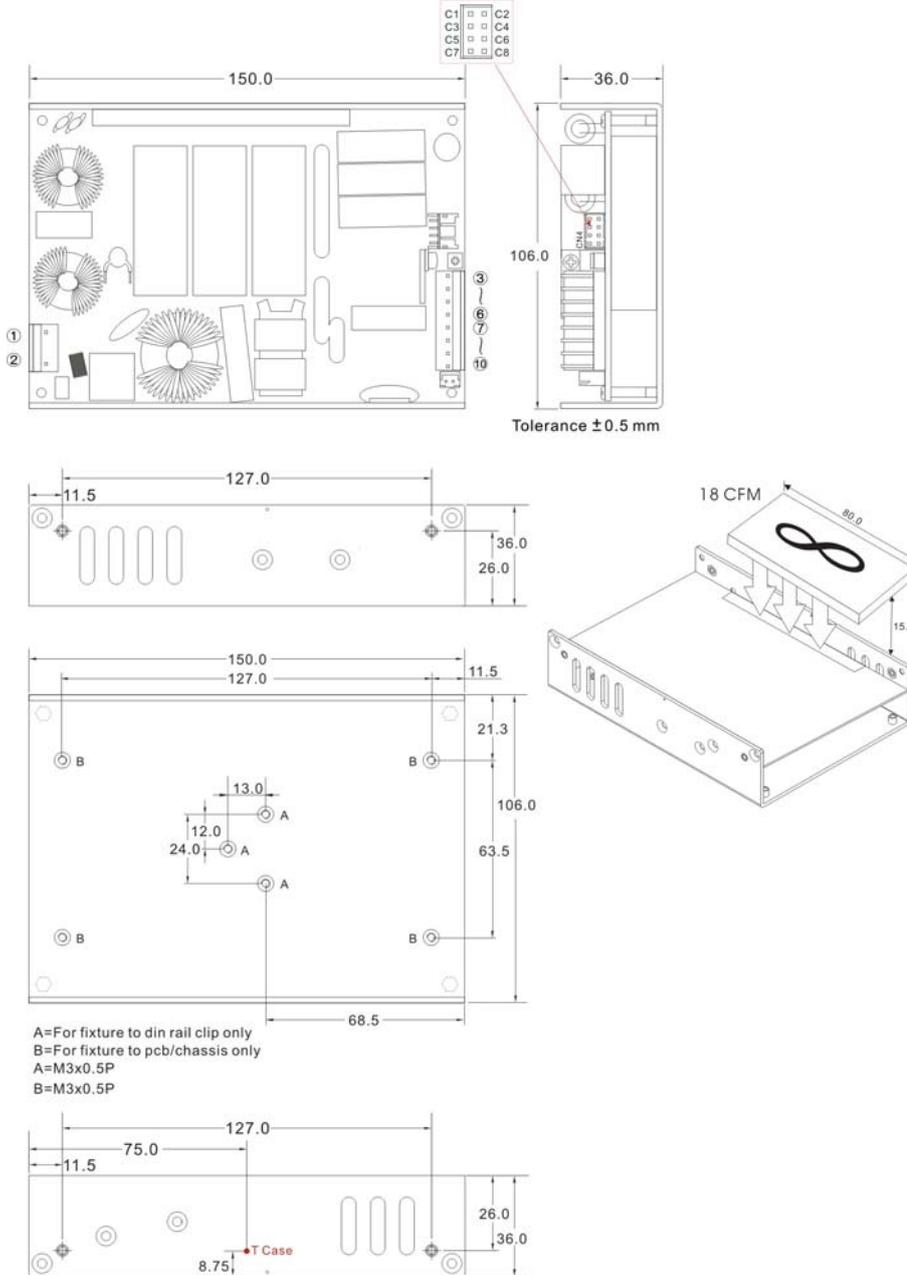
MECHANICAL DIMENSION (Top View)
A Type

Terminal Pin

PIN#	Single
1	AC IN (N)
2	AC IN (L)
3~6	+DC OUT
7~10	-DC OUT

Connector Pin (CN4)

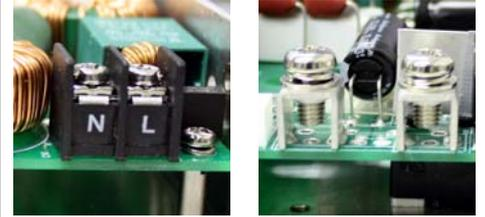
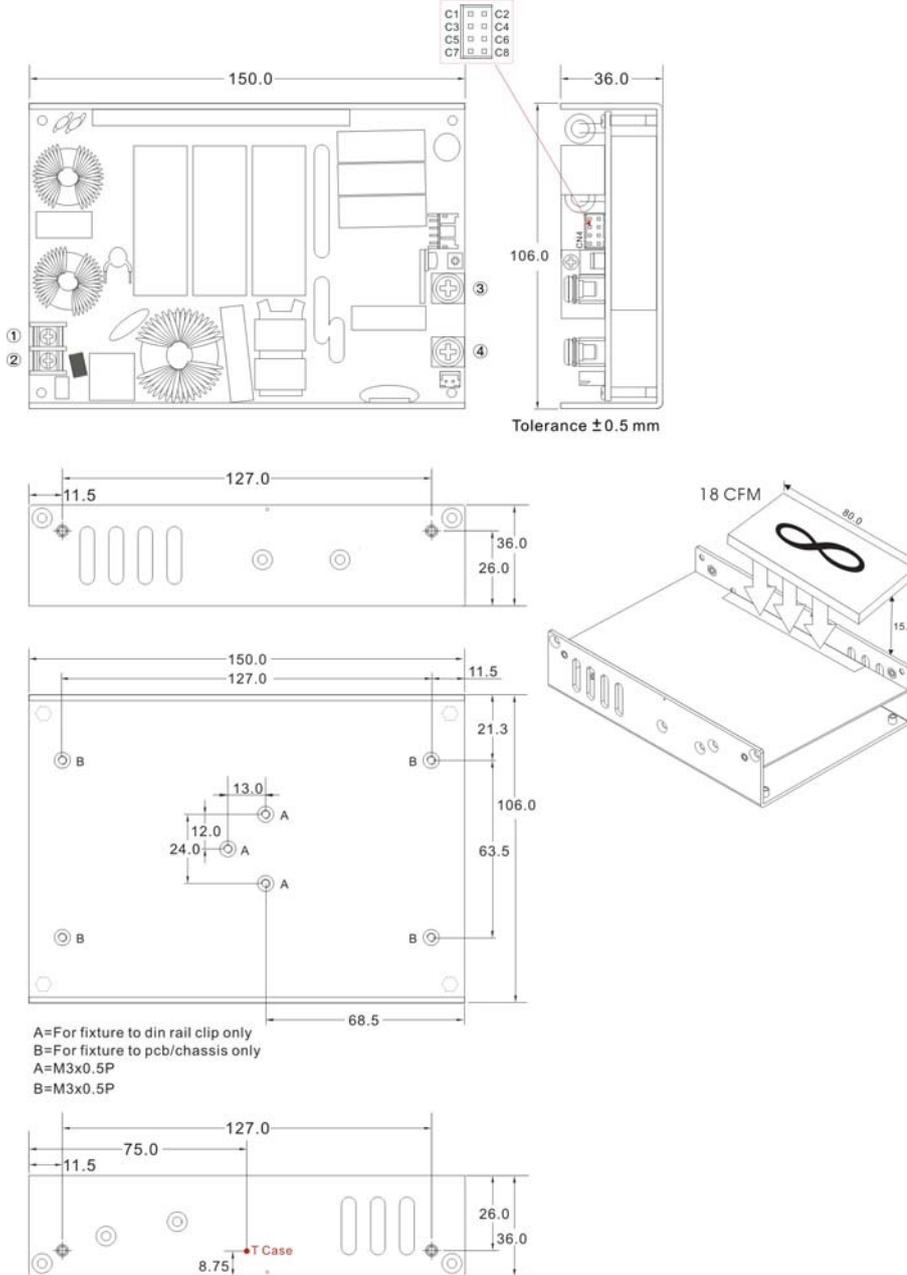
PIN#	Single
C1	NC
C2	-V
C3	NC
C4	NC
C5	ENA
C6	NC
C7	CS
C8	NC

MECHANICAL DIMENSION (Top View)
B Type

Terminal Pin

PIN#	Single
1	AC IN (N)
2	AC IN (L)
3	+DC OUT
4	-DC OUT

Connector Pin (CN4)

PIN#	Single
C1	NC
C2	-V
C3	NC
C4	NC
C5	ENA
C6	NC
C7	CS
C8	NC

FUNCTION DESCRIPITON of CN4 :

Pin No.	Function	Description
C1	NC	
C2	-V	
C3	NC	
C4	NC	
C5	ENA	Open collector (10mA sink current). Low when output is present.
C6	NC	
C7	CS	Current Share function pin
C8	NC	

BLOCK DIAGRAM

